

BASISREGELS VOOR HET DESIGN VAN TE METALLISEREN COMPONENTEN

IS HET DESIGN CORROSIE-VRIENDELIJK?

- Openingen
- Montage
- Transport

slecht

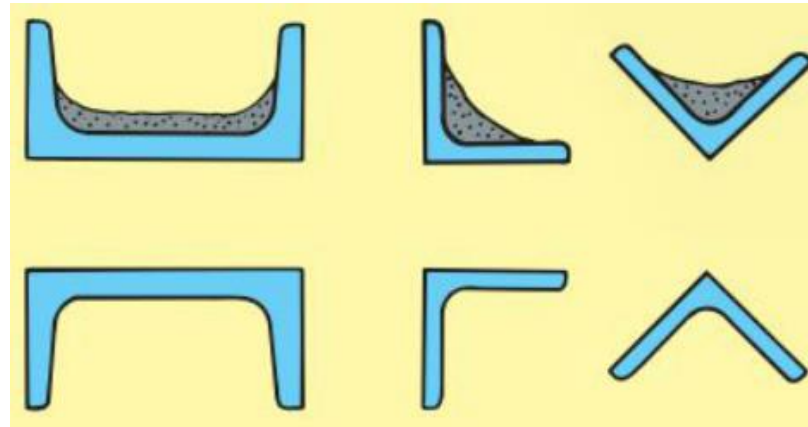

goed



BASISREGELS VOOR HET DESIGN VAN TE METALLISEREN COMPONENTEN

IS HET DESIGN CORROSIE-VRIENDELIJK?

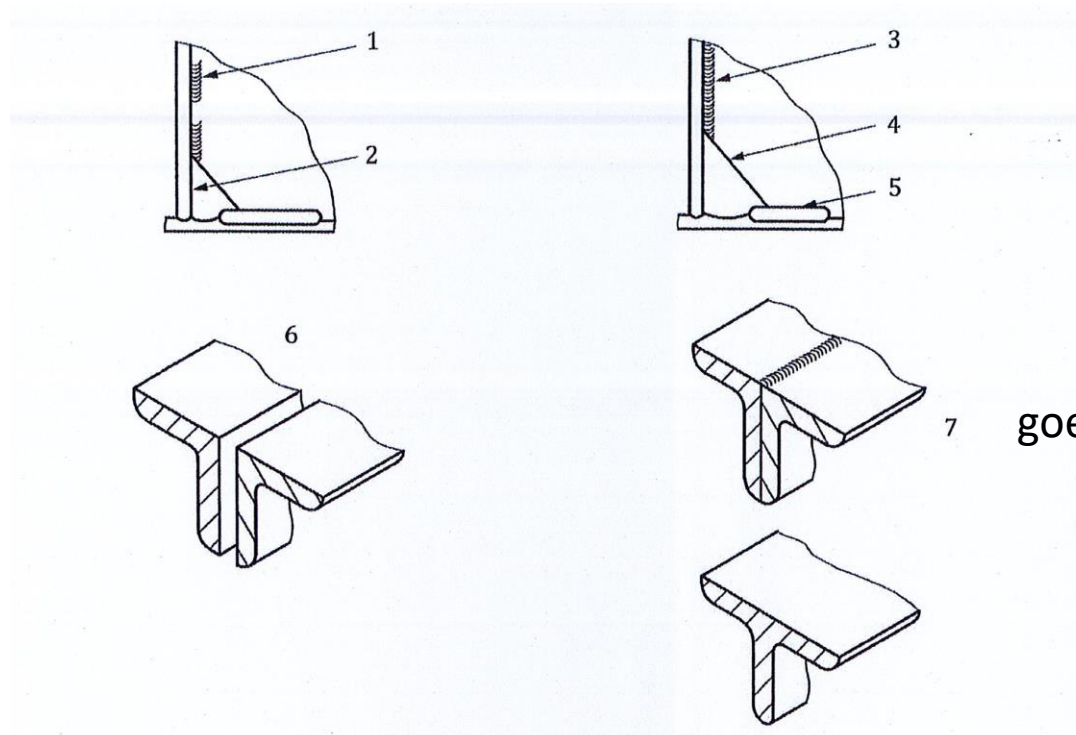

slecht

goed

- 1 Intermittent stiffener welds are to be avoided.
- 2 Stiffening plate close to the flange corner shall be avoided because the gap cannot be coated sufficiently.
- 3 Continuous weld to be preferred.
- 4 Long snipe to give access is to be preferred.
- 5 Packing well away from the weld is to be preferred.
- 6 Back-to-back angles are to be avoided because the gap cannot be coated sufficiently.
- 7 Continuous welds or similar section T-bars are to be preferred.