

## REGLES DE BASE POUR LE DESING DES COMPOSANTS A METALLISER

EST-IL POSSIBLE DE METALLISER?

- Distance
- Coins morts
- Accessibilité
- Sécurité

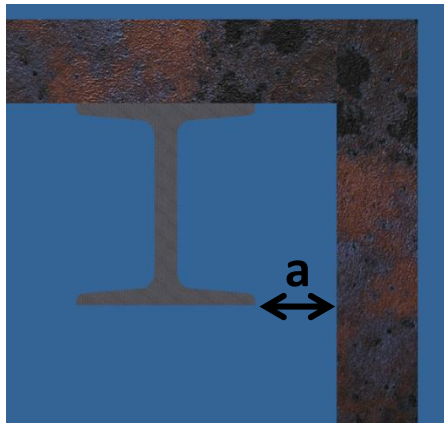

## REGLES DE BASE POUR LE DESING DES COMPOSANTS A METALLISER

EST-IL POSSIBLE DE METALLISER?

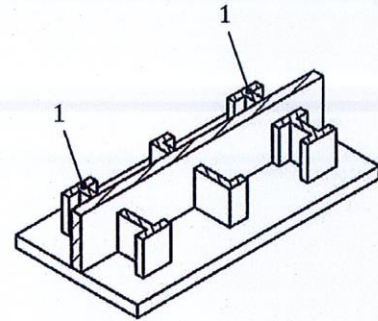

mauvais

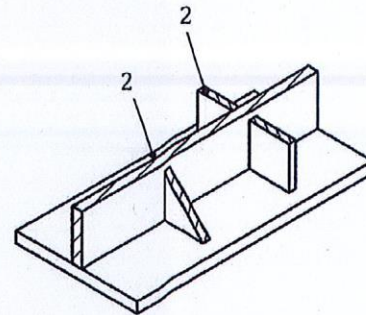

bon

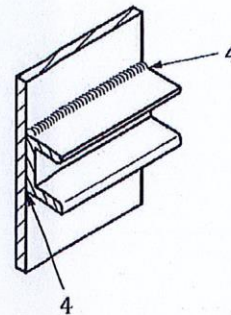
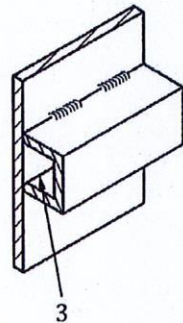

- 1 Small section stiffeners or small U beams or channels are to be avoided.
- 2 Flat steels are to be preferred.
- 3 Shall be avoided, as far as the interior of the U beam had been corrosion protected prior to welding.
- 4 Continuous welds, smooth and cleaned of slag and weld spatter are to be preferred.